



**PRECISION
FLIGHT CONTROLS**

CIRRUS DESKTOP YOKE USER GUIDE

**BEECH
STYLE**



**BOEING
STYLE**



**CIRRUS
FLIGHTSTICK**



**CESSNA
STYLE**



**MOONEY
STYLE**



CONTENTS

1 PRECAUTIONS AND WARNINGS

2 INTRODUCTION

3 HARDWARE INSTALLATION

4 SOFTWARE INSTALLATION

5 LIMITED WARRANTY INFORMATION

1 | PRECAUTIONS & WARNINGS

SAFETY

THIS PRODUCT HAS BEEN DESIGNED WITH CONCERN FOR SAFETY. HOWEVER, ANY ELECTRICAL DEVICE, IF USED IMPROPERLY, HAS THE POTENTIAL FOR CAUSING FIRE, ELECTRICAL SHOCK OR PERSONAL INJURY.

TO HELP ENSURE ACCIDENT-FREE OPERATION, FOLLOW THESE GUIDELINES:

- OBSERVE ALL WARNINGS, PRECAUTIONS AND INSTRUCTIONS.
- REGULARLY INSPECT POWER AND USB CONNECTIONS.
- STOP USE AND DISCONNECT FROM ELECTRICAL OUTLET IMMEDIATELY IF POWER OR USB CONNECTION ARE
- DAMAGED OR IF DEVICE PRODUCES UNUSUAL SOUNDS OR SMELL OR BECOMES HOT TO THE TOUCH.

PRECAUTIONS

BEFORE USING THE PRODUCT, CAREFULLY READ THIS MANUAL AND RETAIN IT FOR FUTURE REFERENCE. IT IS IMPORTANT TO ENSURE THAT ALL USERS FOLLOW SAFETY PRECAUTIONS AND WARNINGS.

WARNINGS

THIS DEVICE IS ONLY FOR FLIGHT SIMULATION USE. NO OTHER USE IS RECOMMENDED.

THIS DEVICE IS FOR INDOOR USE ONLY. DO NOT EXPOSED TO MOISTURE, LIQUID OR HEAT.

THE DEVICE IS NOT A TOY. CHILDREN SHOULD NOT OPERATE IT WITHOUT ADULT SUPERVISION.

MAKE SURE THAT THE DEVICE IS ON A FLAT STABLE SURFACE. FAILURE TO DO SO MAY RESULT IN THE DEVICE FALLING WHICH MAY RESULT BODILY INJURY, DEATH AND DAMAGE TO THE DEVICE.

DO NOT REMOVE THE COVER. OPERATION WITHOUT THE COVER MAY RESULT IN ELECTRIC SHOCK.

DO NOT ATTEMPT TO SERVICE THE DEVICE. REFER SERVICING TO QUALIFIED PERSONNEL ONLY.

DO NOT PLACE DEVICE ON SURFACES THAT ARE UNSTABLE, TILTED OR SUBJECT TO VIBRATION.

DO NOT PLACE THE SYSTEM IN AN AREA SUBJECT TO EXCESSIVE DUST OR CIGARETTE SMOKE. DUST BUILD-UP OR CIGARETTE SMOKE RESIDUE ON THE INTERNAL COMPONENTS MAY CAUSE THE SYSTEM TO MALFUNCTION.

2 | INTRODUCTION

CONGRATULATIONS ON YOUR PURCHASE OF THE PRECISION FLIGHT CONTROLS USB CIRRUS YOKE! THE CIRRUS YOKE FEATURES FOUR DIFFERENT CONTROL WHEELS; THE BEECH, MOONEY, BOEING, CESSNA AND CIRRUS FLIGHT STICK.

THE CONTROL WHEEL IS MOUNTED ON A HARDENED SHAFT THAT IS DRIVEN BY A TWO AXIS PRECISION CONTROL LOADING SYSTEM THAT ENSURES A SMOOTH AND REALISTIC FEEL THROUGHOUT THE CONTROL MOVEMENT.

AVAILABLE AXIS, SWITCHES AND BUTTON:

BEECH AND MOONEY YOKE

- (2) 2-WAY ROCKER SWITCHES
- (2) SINGLE FUNCTION BUTTONS
- (2) AXES

BOEING YOKE

- (1) 2-FUNCTION SPLIT STYLE ROCKER SWITCH*.
- (4) SINGLE FUNCTION BUTTONS
- (2) AXES

CESSNA

- (1) 2-FUNCTION SPLIT STYLE ROCKER SWITCH*.
- (2) SINGLE FUNCTION BUTTONS
- (2) AXES

*NOTE ABOUT SPLIT STYLE SWITCH - YOU MUST PUSH BOTH SWITCHES IN THE SAME DIRECTION TO ACTIVATE THE SWITCH. PUSHING ONE SIDE OF THE SWITCH WILL NOT ACTIVATE THE SWITCH.

DEFINITIONS AND ABBREVIATIONS

USB: UNIVERSAL SERIAL BUS (CONNECTION USED BY CIRRUS YOKE TO THE COMPUTER)

CIRRUS YOKE: THE CIRRUS YOKE WITH ANY CONTROL WHEEL TYPE

DIMENSIONS & WEIGHT

WIDTH: 14.13 IN. / 35.89 CM.

DEPTH: 23.69 IN. / 60.17 CM.

HEIGHT: 5.13 IN / 13.03 CM. (TOP OF CHASSIS ONLY. HEIGHT OF CONTROL WHEEL VARIES)

WEIGHT: 24 LBS / 15.88 KG

3 | HARDWARE INSTALLATION

PACKAGING CONTENTS:

- (1) USB CIRRUS YOKE
- (1) 6 FOOT USB CABLE
- (1) 24 VOLT POWER SUPPLY
- (1) USER'S GUIDE
- (1) USB FLASH DRIVE

PACKAGE INSPECTION

CHECK PACKAGING FOR DAMAGE. DO NOT UNPACK DEVICE IF THERE ARE ANY DAMAGE IN THE PACKAGING. IMMEDIATELY REPORT ANY DAMAGE TO THE CARRIER AND PFC TECHNICAL SUPPORT. TAKE CLEAR PICTURES OF THE DAMAGE AND EMAIL THEM TO TECHSUPPORT@FLYPFC.COM.

ORIGINAL PACKAGING

PLEASE KEEP THE PACKAGING OF YOUR DEVICE UNTIL THE WARRANTY IS NO LONGER IN EFFECT. THE ORIGINAL PACKAGING IS THE BEST PACKAGING SHOULD IT BECOMES NECESSARY TO SEND THE UNIT TO PFC.

COMPATIBILITY

THE CIRRUS YOKE IS COMPATIBLE WITH MS-FSX, PREPAR3D AND X-PLANE 9 AND 10.

INSTALLATION

1. IF THERE ARE NO DAMAGES, CAREFULLY LIFT THE DEVICE OUT OF THE BOX.
2. SET THE YOKE ON TOP OF YOUR TABLE OR DESK.
3. CONNECT THE SQUARE END OF USB CABLE TO THE BACK OF THE YOKE.
4. CONNECT THE FLAT END OF THE USB CABLE TO THE COMPUTER.
5. CONNECT THE POWER CONNECTOR FROM THE POWER SUPPLY TO THE BACK OF THE YOKE.
6. PLUG THE POWER SUPPLY TO THE AC SOCKET.

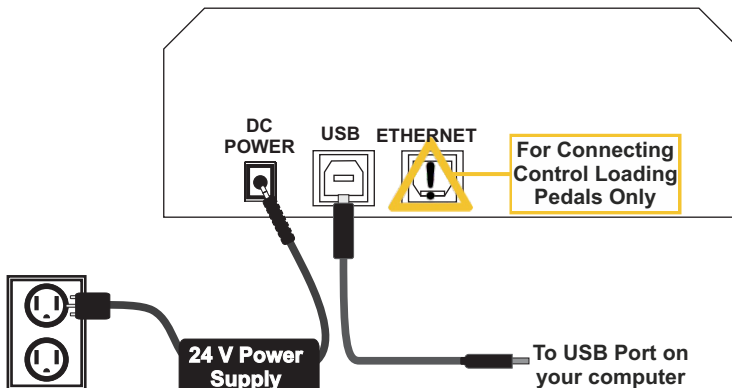

4 | SOFTWARE INSTALLATION

THE CIRRUS YOKE REQUIRES CLS2SIM SOFTWARE FOR PROPER FUNCTIONALITY. THIS SOFTWARE IS THE CONNECTION AND INTEGRATION OF THE ACTIVE FORCE FEEDBACK OF THE CIRRUS YOKE. THIS SOFTWARE SUPPORTS PREPAR3D, MSFSX AND X-PLANE 9/10/11.

THE INSTALLATION AND CONFIGURATION GUIDE FOR CLS2SIM CAN BE FOUND IN THE MEMORY STICK YOU HAVE RECEIVED WITH THE YOKE . PLEASE SEE FILE NAME: ***CLS2SIM-INSTALL-CONFIGURATION.PDF***

5 | LIMITED WARRANTY INFORMATION

WHAT'S COVERED BY OUR LIMITED WARRANTY

PRECISION FLIGHT CONTROLS, INC. (HEREAFTER "PFC") WARRANTS ITS HARDWARE PRODUCTS TO THE ORIGINAL OWNER TO BE FREE FROM DEFECTS IN WORKMANSHIP AND MATERIALS WHEN USED PROPERLY FOR A PERIOD OF ONE (1) YEAR FROM THE DATE OF DELIVERY.

WHAT'S NOT COVERED BY OUR LIMITED WARRANTY

PRODUCT FAILURE DUE TO IMPROPER INSTALLATION, MAINTENANCE, MISUSE, ACCIDENT, ABUSE, NEGLIGENCE, UNAUTHORIZED REPAIR, MODIFICATION OR ALTERATION REMOVAL OR REPLACEMENT COSTS OR LOSS OF REVENUE INCURRED DUE TO DOWNTIME DAMAGE TO RELATED COMPONENTS NORMAL WEAR-AND-TEAR DAMAGE INCURRED DURING SHIPPING TRANSIT, IMPORTATION OR CUSTOMS CLEARANCE PRODUCTS OR SOFTWARE MANUFACTURED BY OTHER COMPANIES SOFTWARE OR DATA LOSS COSMETIC DAMAGES SUCH AS UPHOLSTERY, PAINT, POWDER COAT, STICKERS, WRAPS, SILK SCREEN OR ANY OTHER DAMAGES THAT DO NOT DIRECTLY IMPACT THE USE OF THE PRODUCT IN ITS INTENDED ROLE AS A AVIATION TRAINING DEVICE (ATD) OR GAME CONTROLLER EXPENDABLE ITEMS SUCH AS LIGHT BULBS, BATTERIES AND ETC. LANDING GEAR SWITCH

WHAT PFC WILL DO ON AN APPROVED WARRANTY CLAIM

IF DURING THE WARRANTY PERIOD YOU SUBMIT A WARRANTY CLAIM AND IT IS APPROVED BY PFC, AT PFC'S SOLE DISCRETION WE WILL:

REPAIR THE PRODUCT - USING NEW OR RECONDITIONED PARTS WHICH ARE FUNCTIONALLY EQUIVALENT TO NEW IN PERFORMANCE AND RELIABILITY.

REPLACE THE PRODUCT- USING NEW OR RECONDITIONED PRODUCTS WHICH ARE FUNCTIONALLY EQUIVALENT TO NEW IN PERFORMANCE AND RELIABILITY.

IN THE EVENT A WARRANTY CLAIM IS APPROVED AND THE PRODUCT IS RETURNED DUE TO DEFECT AS STATED ABOVE, A REFUND IN FULL WILL BE ISSUED. IF PRODUCT IS RETURNED WITHIN THE WARRANTY PERIOD, BUT THE RETURN IS NOT RELATED TO DEFECT, A REFUND WILL BE ISSUED LESS A FIFTEEN PERCENT (15%) RESTOCKING FEE.

OBTAINING WARRANTY EVALUATION & SERVICE

ALL WARRANTY QUESTIONS OR CLAIMS MUST FIRST BE DIRECTED TO THE PFC TECHNICAL SUPPORT TEAM. PLEASE BE PREPARED TO PROVIDE THE PFC WITH THE PRODUCT SERIAL NUMBER AND/OR PURCHASE INVOICE NUMBER FOR VERIFICATION. PFC'S TECHNICAL SUPPORT TEAM MAY BE REACHED BY PHONE: (916) 414-1316 OR EMAIL: techsupport@flypfc.com

PFC WILL DETERMINE IF THE PRODUCT HAS FAILED DUE TO DEFECTIVE WORKMANSHIP OR MATERIALS. PFC RESERVES THE RIGHT TO ASSESS FEES ASSOCIATED WITH DIAGNOSTIC SERVICES. IF THE PRODUCT IS DETERMINED TO HAVE AN ISSUE WHICH IS COVERED BY THE WARRANTY, THE CUSTOMER MAY CHOOSE ONE OF SERVICE OPTIONS BELOW:

MAIL IN SERVICE

THIS SERVICE WILL REQUIRE THE CUSTOMER TO SEND THE DEFECTIVE PRODUCT OR PART TO PFC. THE CUSTOMER MUST FOLLOW PFC'S RETURN MATERIAL AUTHORIZATION (RMA) PROCEDURE PRIOR TO RETURNING ANY ITEM. PLEASE NOTE THAT IN THE EVENT AN ITEM IS RETURNED AND THE PACKAGE DOES NOT DISPLAY THE RMA NUMBER (PER THE RMA PROCESS), THE DELIVERY MAY BE REFUSED. FULL INSTRUCTIONS FOR PFC'S RMA PROCESS CAN BE FOUND AT: https://flypfc.com/wp-content/uploads/suppoprtrma_form.pdf

CONTINUED ON NEXT PAGE

ADVANCE REPLACEMENT PART SERVICE

THIS SERVICE ALLOWS OUR CUSTOMERS TO SERVICE THEIR OWN PFC PRODUCT. PFC WILL SEND THE REPLACEMENT PART SO THE CUSTOMER MAY PERFORM THE INSTALLATION OF THE PART. PFC WILL REQUIRE ADVANCE PAYMENT FOR THE PART AND SHIPPING CHARGES. THE ORIGINAL PART MUST BE RETURNED TO PFC VIA A REPUTABLE SHIPPING SERVICE WITHIN TEN (10) BUSINESS DAYS. IN THE EVENT THE CUSTOMER DOES NOT RETURN THE PART WITHIN THE ALLOTTED TIME PERIOD, NO REFUND WILL BE ISSUED.

ON-SITE REPAIR SERVICE

THIS SERVICE IS AVAILABLE FOR ADVANCED AVIATION TRAINING DEVICE (AATD) ONLY. SCHEDULE PERMITTING, PFC WILL SEND A TECHNICIAN TO YOUR LOCATION TO SERVICE THE AATD. AFTER THE FIRST 90 DAYS FROM THE DATE OF SHIPMENT, THE CUSTOMER WILL BE RESPONSIBLE FOR ALL EXPENSES AND LABOR COST FOR THE ON-SITE SERVICE.

WARRANTY FOR REPLACEMENT PARTS OR UNITS

ANY REPLACEMENT PARTS OR UNIT PROVIDED DURING THE WARRANTY PERIOD WILL BE COVERED BY THE REMAINING BALANCE OF TIME ON THE CUSTOMER'S ORIGINAL LIMITED WARRANTY. REPLACEMENT PARTS WILL NOT BE COVERED BY AN EXTENDED OR SEPARATE WARRANTY PERIOD.

RETURN SHIPMENT OPTIONS

PFC, AT ITS OWN EXPENSE, WILL SHIP THE REPAIRED OR REPLACEMENT PRODUCT TO THE CUSTOMER'S ORIGINAL SHIPPING ADDRESS AS REFLECTED ON THE ORIGINAL ORDER/INVOICE. PFC WILL SHIP VIA UPS GROUND OR AN EQUIVALENT SERVICE. IF EXPEDITED SHIPPING IS REQUIRED, THE CUSTOMER WILL BE RESPONSIBLE FOR SHIPPING CHARGES.

THE SELLER DISCLAIMS ANY AND ALL WARRANTIES, EXPRESS OR IMPLIED, STATUTORY OR OTHERWISE, INCLUDING WARRANTIES OF MERCHANTABILITY OR FITNESS FOR A PARTICULAR PURPOSE. SELLER DOES NOT WARRANT THAT THE ANY OF ITS PRODUCTS, ITS USE OR OPERATION OR THE SERVICES PROVIDED UNDER THIS AGREEMENT WILL BE ERROR-FREE, WITHOUT ACCIDENT OR ACHIEVE ANY PARTICULAR GOAL OR RESULT. NO ORAL OR WRITTEN INFORMATION OR ADVICE GIVEN BY AN AUTHORIZED SELLER'S REPRESENTATIVE SHALL CREATE ANY WARRANTY. THIS DISCLAIMER CONSTITUTES AN ESSENTIAL PART OF THIS LIMITED WARRANTY. IN NO EVENT AND UNDER NO LEGAL THEORY SHALL SELLER, ITS OFFICERS, EMPLOYEES OR REPRESENTATIVES BE LIABLE TO BUYER OR ANY OTHER PERSON FOR LOST PROFITS, BUSINESS INTERRUPTION, DAMAGE TO EQUIPMENT, PERSONAL INJURY OR ANY OTHER DIRECT, INDIRECT, INCIDENTAL, CONSEQUENTIAL OR PUNITIVE DAMAGES ARISING OUT OF OR RELATED TO THIS LIMITED WARRANTY OR THE GOODS OR SERVICES SUPPLIED, WHETHER FROM BREACH OF CONTRACT, BREACH OF WARRANTY, TORT (INCLUDING NEGLIGENCE) OR ANY OTHER FORM OF ACTION, EVEN IF SELLER HAS BEEN ADVISED OF THE POSSIBILITY OF SUCH DAMAGES. WITHOUT LIMITING THE FOREGOING, SELLER IS NOT LIABLE FOR BUYER'S IMPROPER USE, INSTALLATION, ACCIDENTS, OPERATION OR MAINTENANCE OF ANY PRODUCT OR OTHER ITEMS MANUFACTURED BY SELLER.

**PRECISION FLIGHT CONTROLS, INC. | 2747 MERCANTILE DRIVE
SUITE 100 | RANCHO CORDOVA CA 95742 | T: 916.414.1310**